

peachtree

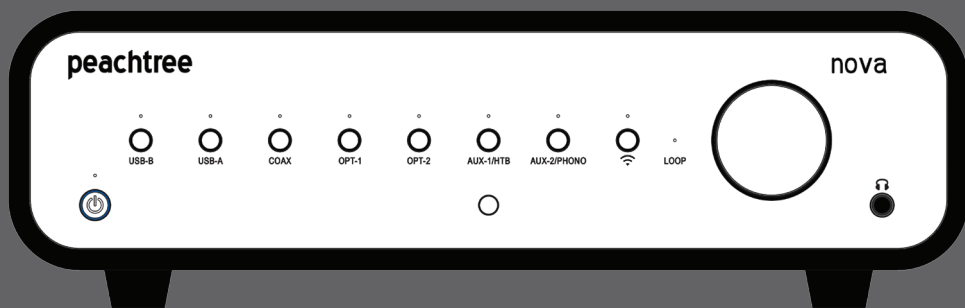

Made for



iPhone



iPad

nova

IMPORTANT SAFETY INSTRUCTIONS

- 1 Read these instructions – All the safety and operating instructions should be read before this product is operated.
- 2 Keep these instructions – The safety and operating instructions should be retained for future reference.
- 3 Heed all warnings – All warnings on the appliance and in the operating instructions should be adhered to.
- 4 Follow all instructions.
- 5 Do not use this apparatus near water – The appliance should not be used near water or moisture – for example, in a wet basement or near a swimming pool, and the like.
- 6 Clean only with dry cloth.
- 7 Do not block any ventilation openings. Install in accordance with the manufacturer's instructions.
- 8 Do not install near any heat sources such as radiators, heat registers, stoves, or other apparatus (including amplifiers) that produce heat.
- 9 Do not defeat the safety purpose of the polarized or grounding plug. A polarized plug has two blades with one wider than the other. A grounding plug has two blades and a third grounding prong. The wide blade or the third prong is provided for your safety. If the provided plug does not fit into your outlet, consult an electrician for replacement of the obsolete outlet.
- 10 Protect the power cord from being walked on or pinched particularly at the plugs, convenience receptacles, and at the point where they exit from the apparatus.
- 11 Only use attachments/accessories specified by the manufacturer.
-  12 Use only with the cart, stand, tripod, bracket, or table specified by the manufacturer, or sold with the apparatus. When a cart is used, use caution when moving the cart/apparatus combination to avoid injury from tip-over.
- 13 Unplug this apparatus during lightning storms or when unused for long periods of time.
- 14 Refer all servicing to qualified personnel. Servicing is required when the apparatus has been damaged in any way such as the power cord or plug is damaged. Other damage may occur if liquid or objects have been dropped or spilled into the apparatus. Dropping the apparatus, exposure to rain, and excessive moisture may cause additional damage.
- 15 Please keep the unit in a good ventilation environment.
- 16 **CAUTION:** These servicing instructions are for use by qualified service personnel only. To reduce the risk of electric shock, do not perform any servicing other than that contained in the operating instructions unless you are qualified to do so.
- 17 **WARNING:** To reduce the risk of fire or electric shock, do not expose this apparatus to rain or moisture. The apparatus shall not be exposed to dripping or splashing and objects filled with liquids, such as vases, shall not be placed on apparatus.

- 18 **WARNING:** The mains plug/appliance coupler is used as disconnect device, the disconnect device shall remain readily operable.

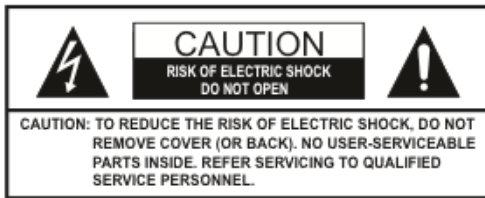

- 19 The lightning flash with arrowhead symbol within an equilateral triangle is intended to alert the user to the presence of non-insulated “dangerous voltage” within the product’s enclosure that may be of sufficient magnitude to constitute a risk of electric shock.

WARNING: To reduce the risk of electric shock, do not remove cover (or back), as there are no user-serviceable parts inside. Refer servicing to qualified personnel.

The exclamation point within an equilateral triangle is intended to alert the user to the presence of important operating and maintenance instructions in the literature accompanying the appliance.

- 20 No naked flame sources, such as lighted candles, should be placed on the apparatus.
- 21 Batteries are included for the remote control. Do not expose these batteries to direct sunlight or excessive heat such as a fire. Care should be taken in the act of battery disposal as they include toxic materials that may harm the environment. Please refer to your local recycling and hazardous waste center for advise with battery disposal.



- 22 **WARNING:** The terminals marked with symbol of “+/-” may be of sufficient magnitude to constitute a risk of electric shock. The external wiring connected to the terminals requires installation by an instructed person or the use of ready-made insulated leads or cords.
- 23 Correct disposal of this product. This marking indicates that this product should not be disposed with other household wastes throughout the EU. To prevent possible harm to the environment or human health from uncontrolled waste disposal, recycle it responsibly to promote the sustainable reuse of material resources. To return your used device, please use the return and collection systems or contact the retailer where the product was purchased. They can take this product for environmentally safe recycling.

Unpacking and Warranty

- 1 Please keep all packing materials for any potential shipping needs.
- 2 Please keep a copy of the sales receipt and note the serial number on it for warranty and insurance purposes.
- 3 Please register your product online at www.peachtreeaudio.com.



Compatible iPod/iPhone Models

Made for iPhone 7 Plus, iPhone 7, iPhone SE, iPad Pro (12.9-inch) 1st generation, iPad Pro (9.7-inch), iPad Air 2, iPad mini 4.

Legal Notice

“Made for iPhone” and “Made for iPad” mean that an electronic accessory has been designed to connect specifically to iPhone or iPad, respectively, and has been certified by the developer to meet Apple performance standards. Apple is not responsible for the operation of this device or its compliance with safety and regulatory standards. Please note that the use of this accessory with iPhone or iPad may affect wireless performance.

Trademark Notice

iPad and iPhone are trademarks of Apple Inc., registered in the U.S. and other countries. iPad Air and iPad mini are trademarks of Apple Inc.

 Marking by the “CE” symbol (shown left) indicates compliance of this device with the EMC (Electromagnetic Compatibility) and LVD (Low Voltage Directive) standards of the European Community.

 Note: This equipment has been tested and found to comply with the limits for a class B digital device, pursuant to part 15 of the FCC Rules. These limits are designed to provide reasonable protection against harmful interference in a residential installation. The equipment generates, uses and can radiate radio frequency energy and, if not installed and used in accordance with the instructions, may cause harmful interference to radio communications. However, there is no guarantee that interference will not occur in a particular installation. If this equipment does cause harmful interference to radio or television reception, which can be determined by turning the equipment off and on, the user is encouraged to try to correct the interference by one or more of the following measures:

- Reorient or relocate the receiving antenna
- Increase the separation between the equipment and the receiver
- Connect the equipment into an outlet on a circuit different from that to which the receiver is connected
- Consult the dealer or an experienced radio/TV technician for help

nova

- ▶ Introduction
- ▶ Back Panel
- ▶ Front Panel
- ▶ Remote Control
- ▶ Home Theater Bypass Input Mode
- ▶ Volume Control Bypass Input Mode
- ▶ Loop Feature
- ▶ Useful Tips
- ▶ Troubleshooting
- ▶ Warranty and Repair
- ▶ Specifications

INTRODUCTION

Thank you for choosing nova! The nova project began as a simple idea with high expectations: design an integrated amplifier platform that connects to every popular Hi-Fi source, plays every type of file put into it, drives any speaker, fills any room, looks great doing it, doesn't cost a small fortune and, most importantly, sounds better than anything in its price range. No easy task, but our team accepted the challenge and set out on a mission to completely re-imagine nova from the ground up. The team poured their heart and soul into every detail, no stone was left unturned and we hope you enjoy using nova as much as we enjoyed creating it!

The nova is several audio components in one. It's a Digital-to-Analog Converter (DAC), line-level preamplifier, phono preamplifier, headphone amplifier and power amplifier all wrapped in an attractive and simple to use package. Each function has been specifically designed to provide the ultimate listening enjoyment, regardless of the input source or the listening method. Each individual function provides a listening experience that compares favorably with dedicated audio components that only perform single functions and cost many times more than an entire nova.

The DAC inside nova is a reference 32-bit/384kHz design that is capable of accepting all of the major file formats currently available in the market today including PCM up to 32-bit/384kHz and DSD up to 5.6MHz. This includes compressed audio, uncompressed audio, high-resolution audio and ultra-high resolution audio. The nova accepts them all! Built around the DAC chip is an extensive, multi-point, regulated power supply that keeps the DAC chip operating optimally and remaining faithful to the input signal, providing the most natural sounding and musical DAC section we have ever designed!

The preamplifier in nova is a full analog design with extremely flexible input and configuration capability. It accepts input from a computer, digital audio devices, analog audio devices, mobile devices and even has a built-in phono preamplifier for connecting a turntable. In addition, there is an optional Peachtree wireless streaming input module that can be installed to add a direct wireless input. The two analog inputs are user-switchable so they can be configured 4 different ways: 2 standard line-level analog inputs, 1 Home Theater Bypass (HTB) input + 1 line-level input, 1 line-level input + 1 phono input, or 1 HTB input + 1 phono input. Your system, your choice! The digital inputs include a user selectable feature called volume control bypass that allows you to control overall system volume right from your connected source device – essentially bypassing the preamplifier in the nova to make it work like a stand-alone power amplifier. This is especially useful if you enjoy using an application on your computer or mobile device to select your music AND to control the volume level. And last, but not least, there is a loop feature that allows an external processor to be integrated with the nova and switched in and out of the signal path by simply

pressing a button on the remote control! In addition to this flexibility, the nova500 preamplifier takes the sound quality to an even higher level by utilizing fully differential (aka balanced) circuitry. This allows the stunning performance of the DAC and preamplifier sections to be retained through the power amplifier section and on to your speakers. The sonic quality of the nova500 is second to none!

The headphone amplifier in nova is specifically designed to be a primary part of the nova design. It is a fully-discrete amplifier design that provides the ultimate listening experience, easily drives any type of headphone, plays as loud as you would likely ever want to, and allows you to hear “further” into your music than you may have ever heard before. When compared to dedicated headphone amplifiers costing many times more than the entire nova, the nova represents an amazing value. The headphone amplifiers in the nova300 and nova500 also provide even more output to enjoy less efficient, harder to drive headphones. When you consider that the nova offers so much more than just a headphone amplifier, the overall value of the nova is remarkable.

The power amplifier sections in the nova are some of the cleanest, neutral, and most powerful ones available today. At an impressive 150 Watts-Per-Channel (WPC) into 8 ohms, the nova150 has plenty of power to satisfy the majority of speakers, rooms and listeners. However, there is no such thing as “too much power” so we also created the nova300 that packs an amazing 300 WPC and the nova500 that offers a staggering 500 WPC that recreates the natural power and dynamics of live music with ease! All of the nova power amplifier sections are fully-differential designs that are extremely faithful to the source, musical and flexible. The new novas are compatible with speakers from 2.5Ω to 16Ω and should have no problem driving the wide range of speakers available today.

Please take the time to read this manual and visit www.peachtreeaudio.com to register your nova. We will extend the standard warranty if you do and your information will not be shared with anyone. We will only contact you with news that is relevant to your nova purchase! If you have additional questions or feedback please contact your reseller or Peachtree Audio directly.

We sincerely hope that you love your nova and that it brings you many years of enjoyment. It represents the very best of everything we do. Thank you again for choosing Peachtree Audio and happy listening!

- Your friends at Peachtree Audio

BACK PANEL

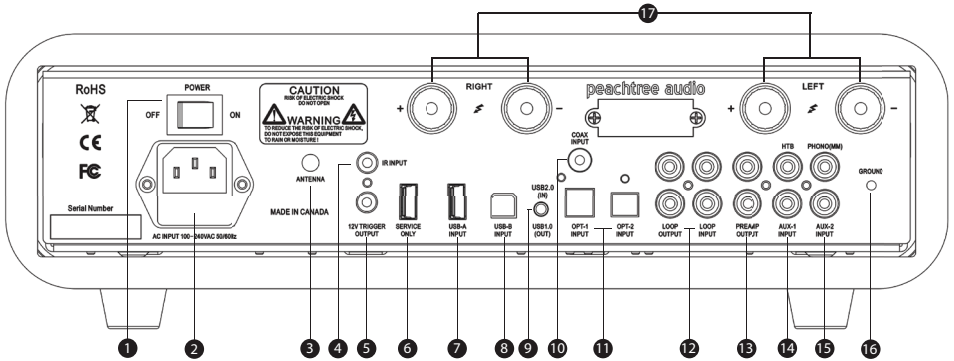

- 1 Power ON/OFF Switch:** Connects and disconnects AC INPUT to the unit when the power cord is connected between the AC INPUT and a 100-240VAC 50/60Hz AC outlet.
- 2 AC INPUT & Fuse Holder:** For connection to a 100-240VAC 50/60Hz AC outlet using the included power cord. The fuse can be replaced after turning the POWER switch OFF and removing the power cord from the **AC INPUT**. See the *SPECIFICATIONS* section for the specific fuse values required for each nova model. *Caution: using an improper fuse value may cause damage to the unit. Peachtree Audio accepts no responsibility for any damage caused by the use of improper fuse values.*
- 3 ANTENNA:** RF input connector for use with the Peachtree wireless streaming input module. Please refer to the instructions included with that module for additional information.
- 4 IR INPUT:** Accepts 3.5mm input from an Infra-Red (IR) repeater/distribution system. Insert one end of a 3.5mm cable into this port and connect the other end to the output of the IR repeater/distribution system. This input allows IR commands to control the unit when the IR window on the front panel is not in “line-of-sight” of the remote control. This is common when the nova is located in an enclosed cabinet or a different room. Please contact us if you need more technical details regarding the IR protocol.
- 5 12V TRIGGER OUTPUT:** Enables power on/off control of another product with a 12V trigger input. Insert one end of a 3.5mm cable into this output and connect the other end to a 12V trigger input of the product to be controlled. Once connected, both products should power on and off when using the nova on/standby button on the front panel or remote control.
- 6 SERVICE ONLY:** *This is NOT a USB audio input!* Reserved for service use. Note: This port may also be used to provide 5V DC to power the optional Peachtree Audio Bt1 Bluetooth module or other USB device that draws up to 5V/500mA (2.5 Watts) of power.
- 7 USB-A INPUT:** Accepts digital audio input from compatible mobile devices. Works with; iPhone 7 Plus, iPhone 7, iPhone SE, iPad Pro (12.9-inch) 1st generation, iPad Pro (9.7-inch), iPad Air 2, iPad mini 4.

- 8 **USB-B INPUT:** Accepts digital audio input up to 32-bit/384kHz PCM and 5.6MHz DSD from a computer when the USB button is set to **USB 2.0** (recommended for all Mac users and Windows users with music files above 96kHz or DSD). Accepts digital audio input up to 96kHz from a computer when the USB button is set to **USB 1.0** (recommended for all Windows users with music files that do NOT exceed 96kHz or DSD). *Windows users note: For playback of files above 96kHz, Windows requires installation of the USB 2.0 driver on your PC before it will be compatible with the USB 2.0 setting. Please visit <http://www.peachtreeaudio.com/support/usb-drivers.html/> to download the latest version.*
- 9 **USB 2.0/1.0 Button:** Toggles the USB-B input between USB 2.0 and USB 1.0 compatibility. All Mac users should set this to **USB 2.0** (in). Windows PC users should set this to **USB 1.0** (out) if using music files that do NOT exceed 96kHz. Windows users should set this to **USB 2.0** (and must install the Windows USB 2.0 driver) if using any music files that exceed 96kHz. *Note: changing the setting while the unit is on will not be active until the unit is cycled through standby mode. It is recommend that the unit be put into standby mode prior to changing this setting.*
- 10 **COAX INPUT:** Accepts S/PDIF digital audio input from a coaxial (RCA style) output up to 192kHz. Coaxial digital audio output is available on many digital audio sources including disc players and some streaming audio devices.
- 11 **OPT-1 & OPT-2 INPUT:** Accepts S/PDIF digital audio input from a optical (Toslink style) output up to 192kHz. Optical digital audio outputs are common on digital audio sources including; streaming audio devices, disc players, cable boxes and HDTVs.
- 12 **LOOP OUTPUT & LOOP INPUT:** This is a loop feature (similar to a processor or tape monitor loop) with an output and input that are tied together to allow an audio processing device to be inserted into the signal path. The loop is active when the LOOP LED on the front panel is lit blue. The loop can only be engaged and disengaged using the LOOP button on the remote control. This makes it easier to compare the original audio signal to the modified audio signal when using the connected device. Please note that when the loop is active, the audio signal from the nova is output on the **LOOP OUTPUT** connectors and the audio signal output from the connected device is looped back into the **LOOP INPUT** connectors on the nova. Improper wiring or use of this feature may result in no audio when the loop is engaged. When the loop is disengaged, the circuit is completely bypassed to shorten the audio signal path and minimize potential interference.
- 13 **PREAMP OUTPUT:** Provides analog audio output to connect to a powered subwoofer or an external power amplifier. Note: the **RIGHT** and **LEFT** speaker outputs remain active when the **PREAMP OUTPUT** is used and both sets of outputs are automatically muted when the mute function is engaged or when headphones are connected to the front panel.
- 14 **AUX-1/HTB INPUT:** Accepts line-level input from an analog audio (RCA style) source. Also, accepts line-level analog audio output from a Surround Sound Processor (SSP) or Audio/Video Receiver (AVR) when set to Home Theater Bypass (HTB). Please see the Home Theater Bypass instructions elsewhere in this manual for more detail.
- 15 **AUX-2/PHONO INPUT:** Accepts line-level input from an analog audio (RCA style) source. Also, accepts analog audio output from a phonograph/turntable with a Moving Magnet (MM) cartridge. Please note that when using a phonograph/turntable with a Moving Coil (MC) cartridge, this input should be set to **AUX-2** and an external phono preamp designed specifically for Moving Coil cartridges used.

Magnet (MM) cartridge. Please note that when using a phonograph/turntable with a Moving Coil (MC) cartridge, this input should be set to **AUX-2** and an external phono preamp designed specifically for Moving Coil cartridges used.

- 16 **GROUND:** Accepts the ground connection from a connected a phonograph/turntable.
- 17 **RIGHT & LEFT SPEAKER Outputs:** Speaker binding post outputs that accept banana connectors (insert into hole on back of the post), spade connectors (loosen, position spade around post, tighten), pin connectors (loosen, insert pin through hole on post, tighten) or bare wire connections (loosen, loop around post or insert through hole on the post, tighten).

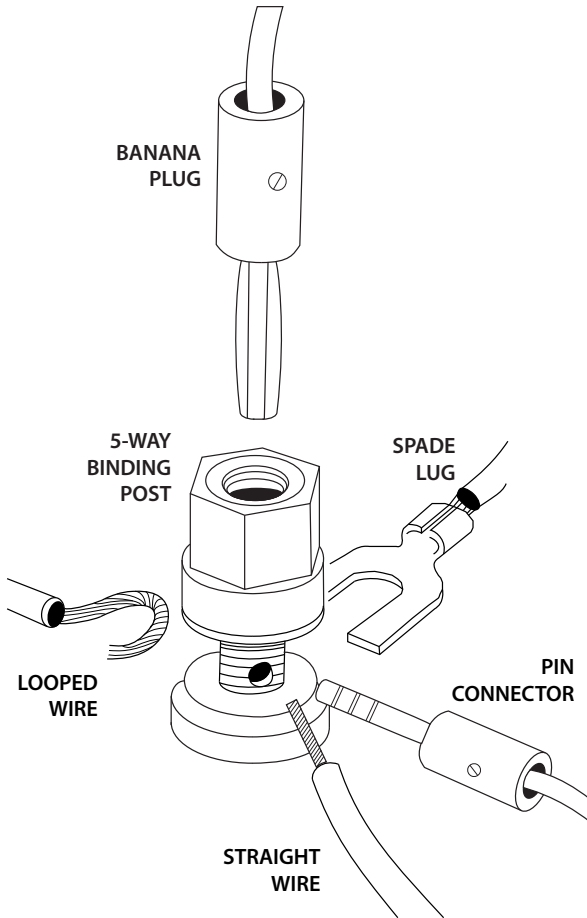

Note: To enable the rear panel IR input connector and disable the front panel IR receiver, press the current input button 10 times in succession until the standby LED blinks 3 times. To disable the rear panel IR input connector and enable the front panel IR receiver, repeat the procedure above until the standby LED blinks 2 times.

FRONT PANEL

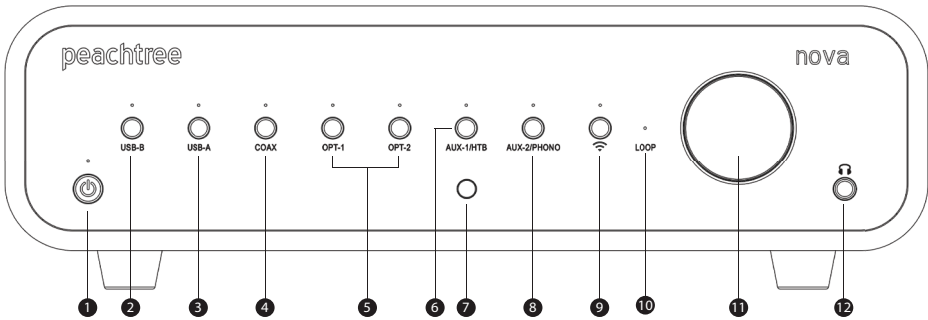

- 1 On/Standby Button:** With the AC power cord connected and the rear panel **POWER** switch set to **ON**, this button toggles the unit between On mode (which selects the last input used) and Standby mode which lights the LED red.
- 2 USB-B Button:** This button selects the **USB-B** input and lights the LED blue (or green if the volume bypass mode is engaged - please see the volume control bypass instructions elsewhere for more detail). Caution: the volume control in the nova is completely bypassed when using the volume control bypass mode!
- 3 USB-A Button:** This button selects the **USB-A** input and lights the LED blue (or green if the volume bypass mode is engaged - please see the volume control bypass instructions elsewhere for more detail). Caution: the volume control in the nova is completely bypassed when using the volume control bypass mode!
- 4 COAX Button:** This button selects the **COAX** input and lights the LED blue (or green if the volume bypass mode is engaged - please see the volume control bypass instructions elsewhere for more detail). Caution: the volume control in the nova is completely bypassed when using the volume control bypass mode!
- 5 OPT-1 & OPT-2 Button:** These buttons select the **OPT-1** and **OPT-2** inputs and light the LED blue (or green if the volume bypass mode is engaged - please see the volume control bypass instructions elsewhere for more detail). Caution: the volume control in the nova is completely bypassed when using the volume control bypass mode!
- 6 AUX-1/HTB Button:** This button selects the **AUX-1** input and lights the LED blue (or green if the Home Theater Bypass mode is engaged - please see the Home Theater Bypass instructions elsewhere for more detail). Caution: the volume control in the nova is completely bypassed in the Home Theater Bypass mode!
- 7 IR Receiver:** Window for receiving Infra-Red (IR) commands from the included remote control or third-party remote control systems. Note: The nova also includes an IR input on the rear panel for receiving wired IR commands from third-party remote control systems.
- 8 AUX-2/PHONO Button:** This button selects the **AUX-2** input and lights the LED blue (or green if the **PHONO** input mode is engaged). **PHONO** input mode is designed to integrate the nova with a Moving Magnet (MM) phonograph/turntable. *Note: When in PHONO input mode, the input has additional gain and equalization settings applied that*

are specifically designed for MM cartridges. Please note that when using a phonograph/turntable with a Moving Coil (MC) cartridge, this input should be set to **AUX-2** and an external phono preamp designed specifically for Moving Coil cartridges used. Press and hold this button for ~10 seconds to toggle the input between the **AUX-2** (blue LED) and **PHONO** (green LED) input modes.

- 9 **Wi-Fi Button:** This button selects the Peachtree wireless streaming input module (if installed) and lights the LED blue (or green if the volume bypass mode is engaged - please see the volume control bypass instructions elsewhere for more detail). Caution: the volume control in the nova is completely bypassed when using the volume control bypass mode! If the wireless streaming input module is not installed, this button has no function.
- 10 **LOOP LED:** Indicates if the LOOP OUTPUT/LOOP INPUT is engaged (lit blue) or disengaged (off). Note: the loop can only be engaged and disengaged using the LOOP button on the remote control.
- 11 **Volume Knob:** Rotate clockwise to increase and counter-clockwise to decrease output level. Press to toggle mute on and off. Note: the volume level will be indicated for ~2 seconds using the 8 blue input LEDs on the front panel. Each one represents ~12.5% of the volume range. *Note: the currently selected blue or green input LED will flash slowly while the unit is muted. Whenever the nova is making output level changes automatically, the input LEDs will blink. The blinking stops when the nova reaches the correct output level. This occurs when mute is disengaged, volume control bypass is selected and/or home theater bypass is selected. This is to minimize the chance of sudden, unexpected output level changes.*
- 12 **Headphone Output:** 1/4" headphone output connection. Inserting a headphone connection automatically mutes the **RIGHT & LEFT Speaker** and **PREAMP OUTPUTS**. Removing a headphone connection automatically un-mutes the **RIGHT & LEFT Speaker** and **PREAMP OUTPUTS**. Caution: Please lower the output level when inserting or removing headphone connections as headphone sensitivity varies widely and a comfortable speaker listening level may be extremely loud when switching to headphones.

Note: To enable the rear panel IR input connector and disable the front panel IR receiver, press the current input button 10 times in succession until the standby LED blinks 3 times. To disable the rear panel IR input connector and enable the front panel IR receiver, repeat the procedure above until the standby LED blinks 2 times.

REMOTE CONTROL

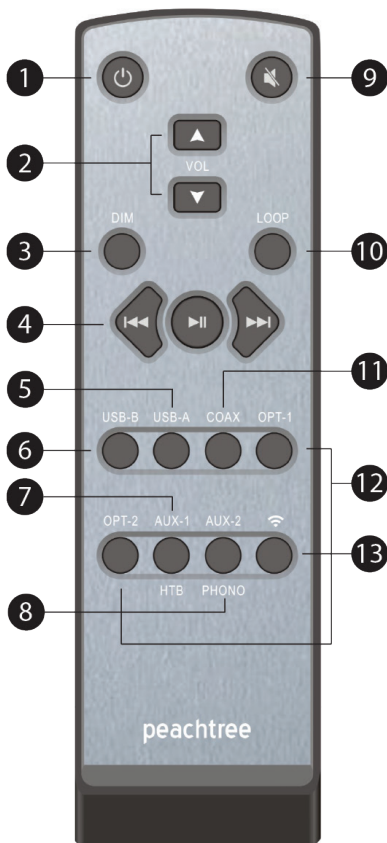

1 On/Standby Button: With the AC power cord connected and the rear panel **POWER** switch set to **ON**, this button toggles the unit between On mode (which selects the last input used) and Standby mode which lights the LED red. *Note: it takes ~2 seconds for the unit to fully transition from standby to on mode. During this time, any commands will not be acknowledged.*

2 Volume +/-: Increases and decreases the output level. *Note: the volume level will be indicated for ~2 seconds using the 8 blue input LEDs on the front panel. Each LED represents ~12.5% of the entire volume range. Note: the currently selected blue or green input LED will flash slowly while the unit is muted. Whenever the nova is making output level changes automatically, the input LEDs will blink. The blinking stops when the nova reaches the correct output level. This occurs when mute is disengaged, volume control bypass is selected and or home theater bypass is selected. This is to minimize the chance of sudden, unexpected output level changes.*

3 DIM Button: Dims the front panel LED brightness. *Note: the brightness will continually cycle through all of the available settings: maximum, high, medium, low, maximum, high...*

4 Transport Control Buttons: Controls playback of compatible devices connected to a USB input (USB-A for iOS devices and USB-B for personal computers). ◀◀ selects the previous track or the beginning of the current track if playback is in progress. ▶◥ toggles between play mode and pause mode. ▶▶ selects the next song in the current track queue or list. *Please note that some USB capable devices and applications may not support these controls. This is not a malfunction of the remote control. If the USB device does not respond to these commands, it is due to the connected device or application not supporting them.*

5 USB-A Button: This button selects the **USB-A** input and lights the LED blue (or green if the volume bypass mode is engaged - please see the volume control bypass instructions elsewhere for more detail). Caution: the volume control in the nova is completely bypassed in the volume control bypass mode!

6 USB-B Button: This button selects the **USB-B** input and lights the LED blue (or green if the volume bypass mode is engaged - please see the volume control bypass

instructions elsewhere for more detail). Caution: the volume control in the nova is completely bypassed in the volume control bypass mode!

- 16 **GROUND:** Accepts the ground connection from a connected a phonograph/turntable.
- 7 **AUX-1/HTB Button:** This button selects the **AUX-1** input and lights the LED blue (or green if the Home Theater Bypass mode is engaged - please see the Home Theater Bypass instructions elsewhere for more detail). Caution: the volume control in the nova is completely bypassed in the Home Theater Bypass mode!
- 8 **AUX-2/PHONO Button:** This button selects the **AUX-2** input and lights the LED blue (or green if the **PHONO** input mode is engaged). **PHONO** input mode is designed to integrate the nova with a Moving Magnet (MM) phonograph/turntable. Note: When in **PHONO** input mode, the input has additional gain and equalization settings applied that are specifically designed for MM cartridges. Please note that when using a phonograph/turntable with a Moving Coil (MC) cartridge, this input should be set to **AUX-2** and an external phono preamp designed specifically for Moving Coil cartridges used. Press and hold this button for ~10 seconds to toggle the input between the **AUX-2** (blue LED) and **PHONO** (green LED) input modes.
- 9 **MUTE Button:** Mutes and un-mutes the **RIGHT & LEFT Speaker, PREAMP** and headphone outputs. Note: the currently selected blue or green input LED will flash slowly while the unit is muted.
- 10 **LOOP Button:** Engages and disengages the LOOP OUTPUT/LOOP INPUT. Note: The LOOP LED on the front panel is lit blue whenever the loop is engaged.
- 11 **COAX Button:** This button selects the **COAX** input and lights the LED blue (or green if the volume bypass mode is engaged - please see the volume control bypass instructions elsewhere for more detail). Caution: the volume control in the nova is completely bypassed in the volume control bypass mode!
- 12 **OPT-1 & OPT-2 Button:** These buttons select the **OPT-1** and **OPT-2** inputs and light the LED blue (or green if the volume bypass mode is engaged - please see the volume control bypass instructions elsewhere for more detail). Caution: the volume control in the nova is completely bypassed in the volume control bypass mode!
- 13 **📶 Button:** This button selects the Peachtree wireless streaming input module (if installed) and lights the LED blue (or green if the volume bypass mode is engaged - please see the volume control bypass instructions elsewhere for more detail). Caution: the volume control in the nova is completely bypassed in the volume control bypass mode! If the wireless streaming input module is not installed, this button has no function.

HOME THEATER BYPASS INPUT MODE

The nova includes a Home Theater Bypass (HTB) input mode that is designed to integrate the nova with a “surround-sound” system to utilize the amplifier in the nova to power the front left and right speakers for all sources. When **AUX-1** is set to HTB input mode, the signal passes from the front left and right analog outputs of the Surround-Sound Processor (SSP) or Audio-Video Receiver (AVR) directly to the power amplifier of the nova and the speakers connected to it. This allows the nova to be enjoyed as an “audio-only” system with the sources connected to it and to also be utilized when playing video sources connected to your SSP or AVR. When this input is set to HTB input mode, the LED is lit green - indicating that the nova’s volume control is bypassed and the volume control in the SSP or AVR must be used to control the overall system volume level. When this input is set to **AUX-1**, the LED is lit blue - indicating that the nova’s built-in volume control is in the signal path and should be used to control overall volume level of the source connected to this input.

To set up Home Theater Bypass:

1. Turn off the Surround-Sound Processor (SSP) or Audio-Video Receiver (AVR) and the nova.
2. Connect the front LEFT and RIGHT preamp output from the SSP or AVR to the **AUX-1/HTB** input on the nova.
3. Turn on the nova and select the **AUX-1/HTB** input.
4. Press and hold the **AUX-1/HTB** button for ~5 seconds to engage the HTB input mode, indicated by the input LED turning green.
5. Turn on your SSP or AVR and calibrate its output levels with the HTB input on the nova selected. This will ensure that the relative output levels of all the speakers are maintained when watching video.

When listening to sources connected to your SSP or AVR, simply select the **AUX-1/HTB** input on the nova. When listening to any other sources connect to the nova, simply press the corresponding input button.

Caution: when the nova is in HTB input mode, the SSP or AVR is in complete control of the overall system volume level. If extra care is not taken, significant damage to the speakers or power amplifier may occur. Peachtree Audio does not accept any responsibility for damage caused by improper setup or use of this feature.

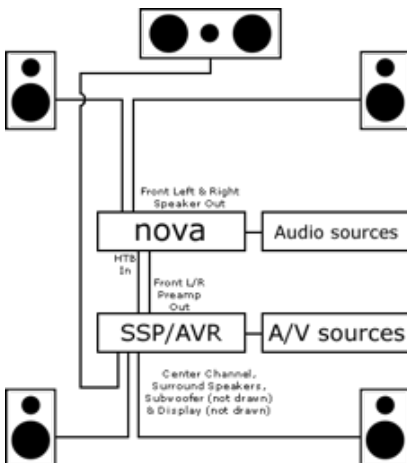

Connect Line-level (RCA style) front left and right outputs from the SSP or AVR to the **AUX-1/HTB** input on the nova.

VOLUME CONTROL BYPASS INPUT MODE

The nova includes a Volume Control Bypass (VCB) input mode that removes the built-in output level control from the signal path. This is useful when using digital sources that have their own volume control built in that you prefer to use for convenience. When an input is selected, the LED will light blue if VCB mode is disengaged (the built-in volume control is in the signal path) or green if VCB mode is engaged (the volume control in the source device must be used).

To set up Volume Control Bypass mode:

1. Make sure the connected device is set to a low volume level!
2. Press and hold the desired input button for ~5 seconds to engage the VCB input mode, indicated by the input LED turning green. Note: repeat this step to disengage the VCB input mode, indicated by the input LED turning blue. VCB input mode disengaged is the factory default setting.

The Volume Control Bypass feature is not available on the AUX-2/PHONO input. Pressing and holding the AUX-2/PHONO input button for ~10 seconds toggles the input mode between AUX-2 and PHONO. This feature is unique to the AUX-2/PHONO input.

Caution: when the nova is in VCB input mode, the source device is in complete control of the output level sent to the power amplifier and speakers. If extra care is not taken, significant damage to the speakers or power amplifier may occur. Peachtree Audio does not accept any responsibility for damage caused by improper setup or use of this feature.

LOOP FEATURE

LOOP OUTPUT & LOOP INPUT: This is a loop feature (similar to a processor or tape monitor loop) with an output and input that are tied together to allow an audio processing device to be inserted into the signal path of the currently selected input. The loop is active when the LOOP LED on the front panel is lit blue. The loop is engaged and disengaged using the LOOP button on the remote control. This makes it easier to compare the original audio signal to the modified audio signal from the connected device from your listening position. Please note that when the loop is active, the audio signal from the nova is output on the **LOOP OUTPUT** connectors and the audio signal output from the connected device is looped back into the **LOOP INPUT** connectors on the nova. Improper wiring or use of this feature may result in no audio when the loop is engaged. When the loop is disengaged, the circuit is completely bypassed to shorten the audio signal path and minimize potential interference.

To set up Volume Control Bypass mode:

1. Turn off the nova and the device to be connected.
2. Connect the **LOOP OUTPUT** connections on the nova to the input connections on the external processing device.
3. Connect the output connections on the external processing device to the **LOOP INPUT** connections on the nova.
4. Turn on the nova and the connected device.
5. Using the nova remote control, press the LOOP button to engage and disengage the connected device from the signal path.

USEFUL TIPS

At Peachtree Audio we believe all products should be easy to use, but sometimes getting the audio to stream out of a computer's USB port requires a few extra steps. See instructions below. Some minor changes may occur with Windows or Apple OS updates, but the basics are the usually the same.

USB Connections

Windows PC

- 1 Connect the USB-B input on the nova to an open USB port on your computer.
- 2 Your computer should "recognize" the nova as a USB device. You might even get a pop-up window notifying you.
- 3 Right click the speaker icon on your screen.
- 4 Select the "AUDIO" tab.
- 5 Using the drop-down menu, choose the Peachtree Audio option.
- 6 Click "OK."
- 7 You will need to install the included USB 2.0 driver for playback of music files that exceed 96kHz when using a Windows PC.

Launch your music application and enjoy!

Mac

- 1 Open System Preferences.
- 2 Click on Sound.
- 3 In the output tab you should see Peachtree as one of the choices.
- 4 Select it.

Launch iTunes or other music application and enjoy!

Once you set up your computer using the instructions above, it should automatically recognize the nova each time you use it. If you unplug the USB connection or re-boot your computer, you may have to repeat some of the steps above. This is typical.

Other useful tips...

For the best sound when listening to music from your computer, set your computer and music program volume controls to maximum and use the nova volume knob or remote control as the master volume control.

For critical listening to music from your computer, avoid keeping multiple programs open. It can compromise the sound quality and even cause signal dropouts.

Provide adequate ventilation above the nova so it can "breathe."

Please check www.peachtreeaudio.com periodically for additional tips and articles.



Interested in the Green Movement?

- The nova meets European RoHS standards for non-hazardous metals
- The nova draws less than half a watt of power in standby mode
- The internal power amplifier is set to minimize power consumption when headphones are used
- We are committed to continue exploring additional methods for making our products even more environmentally friendly

TROUBLESHOOTING

ISSUE	SOLUTIONS
The nova will not power on	Check that the power switch on the back panel is on. If it is, the on/standby LED on the front panel LED should be lit red. Check that the AC outlet is functioning correctly by plugging in a lamp or other device to confirm its operation.
The nova powers on, but there is no sound	Check that the nova is not muted (blinking input LED) or headphones connected to the front panel (speaker and preamp outputs muted). Be sure your input source is powered on and playing at a reasonable volume level. Disengage the loop function to see if that resolves the issue. Double-check the connections on the rear panel.
The remote control does not work	Check the remote control batteries by removing the cover on the back trying new ones. Make sure the remote control has a clear “line of sight” to the sensor on the front panel. Check that no powerful light sources, like direct sunlight, is interfering with the sensor on the front panel.
The USB signal from a computer is intermittent	Try re-launching the music application (iTunes, etc.). If the computer doesn’t recognize the nova, unplug the USB cable from the computer and the nova, wait a few seconds, then reconnect the USB cable. Try re-starting the computer. The nova is designed to remain locked on USB signals at all times, but computers drop connections occasionally and require prompts to re-connect.
There is hum/noise when using a computer	If you have music files available on a laptop computer, play them while running the computer on its battery power only. If the hum/noise disappears, then the ground connection on the computer’s AC adapter is introducing a “ground loop” into the system. This is not unusual, but the USB input on the nova is designed to minimize the potential. If the issue persists, please contact your reseller or Peachtree Audio.
There is a “click” or “pop” when using the front panel controls.	Sometimes static buildup on your hand will discharge into the unit when touched and cause an audible click or pop noise. This is normal and happens most frequently in low humidity environments and rooms with carpets. If the unit is behaving erratically afterwards, power it down completely by turning off the rear panel AC switch, letting it sit for a minute or so, then powering it back on. If the issue persists, please contact your reseller or Peachtree Audio.

If something is connected to the USB-A port that does not support audio (Apple Watch Magnetic Charger for example), the red standby LED will flash in sequence: 5 quick flashes, pause, 5 quick flashes, pause...until it is disconnected. Note that while connected, 5V is provided to the device. For example, the Apple Watch Magnetic Charger will still charge the Apple Watch if it is attached.

To disable the “power failure mute” feature, press and hold the volume control knob in for ~15 seconds, until the standby LED blinks 5 times. This is useful in some instances where electrical interference on the AC Mains causes random unexpected loss of audio. Pressing and holding the knob in for ~15 seconds again reverts to the factory default mode (4 blinks). Note that disabling the “power failure mute” can cause noise in the speakers if AC mains power suddenly is removed (when a power failure occurs for example).

WARRANTY AND REPAIR

International Warranty

Peachtree Audio warrants this product for two (2) years, parts and labor, from the original date of purchase from an authorized Peachtree Audio re-seller. If you register your product online at www.peachtreeaudio.com/support/product-registration.html/, the warranty is extended to three (3) years, parts and labor.

Peachtree Audio reserves the right to refuse any warranty claims if coverage cannot be verified by a valid proof of sale or serial number.

Peachtree Audio assumes no responsibility for product failures caused by accident, neglect, misuse, modification or unauthorized repair.

Warranty does not cover shipping costs.

Visit www.peachtreeaudio.com for complete warranty details.

Repair Process

In the event that a product fails, please repack it in its original carton and contact an authorized Peachtree reseller for further instructions. If the reseller is unable to assist, please contact Peachtree Audio directly at service@peachtreeaudio.com or +1-704-391-9337 to obtain a Return Authorization (RA) number *prior* to shipping the product.

Any products received without an RA number may be misdirected and repair delayed.

If a RA number is issued by Peachtree Audio, please ship the product using FedEx or UPS. Do not ship using a Postal Service.

Peachtree Audio assumes no responsibility for products in transit. Please insure the shipment for the product's replacement value in the unlikely event it is lost, stolen or damaged in transit.

US Shipping Address:

Peachtree Audio
12777 East Independence Blvd
Suite C
Matthews NC 28105
USA
RA# _____

www.peachtreeaudio.com

SPECIFICATIONS

SPEAKER OUTPUT	nova150	nova300	nova500
Compatible Speakers	2.5-16Ω		
Output Power (WPC, 8Ω 4Ω, <1% THD+N, AES17)	150 250	300 450	500 800
Dynamic Range (A-weighted)	105dB		106dB
Damping Factor (1kHz)	>600 (8Ω)	>625 (8Ω)	>650 (4Ω)
Frequency Response (20 - 20kHz)	<+/-0.4dB		
Inter-Modulation Distortion (TBD)	>80dB below fundamental		
Total Harmonic Distortion (AES17, 1kHz, 4Ω)	0.008%	0.005%	0.003%
Channel Separation (1kHz, 8Ω)	>90dB		

PREAMP OUTPUT

Output Voltage (rms)	3.8V		
Output Impedance	100Ω		
Signal-to-Noise Ratio (Analog Digital Source, un-weighted)	105dB 105dB		106dB 106dB
Channel Separation (1kHz)	>115dB at 1kHz		
Frequency Response (Analog Digital Source, 8Hz-20kHz)	<0.1dB <0.5dB		
Total Harmonic Distortion	0.003% (2V rms, 1kHz, un-weighted)		0.001% (2V rms, 1kHz, un-weighted)

HEADPHONE OUTPUT

Output Power (32Ω, rms peak)	750mW 1600mW	1200mW 2770mW	
Output Power (300Ω, rms peak)	130mW 275mW	330mW 700mW	
Output Power (600Ω, rms peak)	64mW 135mW	170mW 350mW	
Output Impedance	1Ω		
Signal-to-Noise Ratio (Analog Digital Source, un-weighted)	107dB 106dB		
Dynamic Range (Analog Digital Source, un-weighted)	107dB 100dB		
Channel Separation (1kHz)	>100dB at 1kHz		
Frequency Response (Digital source, 8Hz-20kHz)	<0.5dB		
Frequency Response (Analog source, 8Hz-100kHz)	<0.1dB		
Total Harmonic Distortion	0.003% (2V rms, 1kHz, un-weighted)		

USB-B Input

Formats	PCM and DSD
PCM Sampling Rate and DSD Frequency Rate	16-32 Bit, 44.1-384kHz PCM and 2.8224-5.6448MHz DSD

COAX and OPT Inputs

Formats	16-24 Bit, 44.1-192kHz PCM
---------	----------------------------

AUX Inputs

Maximum Voltage (rms peak-to-peak)	3.5V 10V
Impedance	100kΩ

PHONO Input

Maximum Input Voltage (rms)	120mV
Impedance	47kΩ
RIAA EQ	No rumble filter used

Loop Output and Input

Maximum Voltage (rms peak-to-peak)	3.5V 10V
Impedance (input output)	100kΩ 100Ω

AC Power

AC Input	100-240VAC, 50/60Hz		
Maximum Power Consumption	400W	1200W	1500W
On Mode (Idle) Power Consumption	15W	32W	41W
Standby Mode Power Consumption	<0.5W		
Fuse	100-120VAC: 6.3A/250V IEC time lag high breaking capacity 220-240VAC: 3.15A/250V IEC time lag enhanced breaking capacity	100-120VAC: 8A/250V Medium Acting 220-240VAC: 4A/250V Medium Acting	100-120VAC: 10A/250V Medium Acting 220-240VAC: 6.3A/250V Medium Acting

Physical

Height (including feet)	111 mm 4.37 inches		
Width	356 mm 14.02 inches		
Depth (including volume knob and speaker binding posts)	336.55 mm 13.25 inches	361.95 mm 14.25 inches	
Weight (shipping)	15 lbs (19 lbs) 6.8 kg (8.6 kg)	17 lbs (21 lbs) 7.7 kg (9.5 kg)	19 lbs (23 lbs) 8.6 kg (10.5 kg)

All specifications subject to change without notice.

peachtree



Made for
 iPhone  iPad

nova